



786PF

Service Manual

PROVIEW ELECTRONICS CO.,LTD

6F,No.1,Pau-Sheng Road,Yung-Ho City,Taipei 234,Taiwan

Tel : (886-2) 2231-6789 , Fax :(886-2) 2231-5678

TABLE OF CONTENTS

SERVICE WARNING	1
A. IMPORTANT SAFETY INSTRUCTION	1
B. SPECIFICATIONS	2
C. TIMING CHART	5
D. CONTROL LOCATION	6
E. ADJUSTMENT CONTROL LOCATION	7
F. ADJUSTMENT PROCEDURE	8
G. BLOCK DIAGRAM	13
H. TROUBLE SHOOTING HINTS	19
I. REPLACEMENT PARTS LIST	27
J. CONDUCTION VIEW	59
K. SCHEMATIC DIAGRAM	61

WARNING

To prevent from fire or shock hazard,do not expose monitor to any rain or any form of water.High voltage is inside the monitor so please do not remove the back cover of the cabinet if you are not a qualified monitor engineer.

Contact the local dealer or the nearest **MAG** branch office if you need help.

A. IMPORTANT SAFETY INSTRUCTION

Prior to using this service manual,please ensure that you have carefully followed all the procedures outlined in the user's manual for this product.

1. Read all of these instructions.
2. Save these instructions.
3. Follow all warnings and instructions a marked on the product.
4. Unplug this product from the wall outlet before cleaning.Do not use liquid cleaners or aerosol cleaners, use a damp cloth for cleaning.
5. Do not use this product near water.
6. Do not place this product on an unstable cart,stand or table.The product may fall,causing serious damage to the product.
7. Slots and openings in the cabinet and the back or bottom are provided for ventilation,to ensure reliable operation of the product and to protect it from overheating,those openings must not be blocked or covered.The openings should never be blocked by placing the product on a bed,sofa, rug, or other similar surface.This product should not be placed in a built-in installation less proper ventilation is provided.
8. This products should be operated from the type of power source indicated on the marketin label. If you are not sure of the type of power available, consult your dealer or local power company
9. This product is equipped with a 3-wire grounding type plug,a plug having a third (grounding) pin.This plug will only fit into a grounding-type power outlet.This is a safety feature,if you are unable to insert the plug into the outlet,contact your electrician to replace your obsolete outlet.Do not defeat the purpose of the grounding-type plug.
10. Do not allow anything to rest on the power cord.Do not locate this product where persons will walk on the cord.
11. If an extension cord is used with this product,make sure that the total of the ampere ratings on the product plugged into the extension cord to the waplugged into outlet does not exceed 15 ampere.
12. Never push objects of any kind into this product through cabinet slots as they may touch dangerous voltage points or short out parts that could result in a risk of fire or electric shock.Never spill liquid of any kind on the product.
13. Do not attempt to service this product yourself,as opening or removing covers may expose you to dangerous voltage points or other risks.Refer all servicing to service personnel.
14. Unplug this product from the wall outlet and refer servicing to qualified service personnel under the following conditions.
 - a. When the power cord or plug is damaged or frayed.
 - b. If liquid has been spilled into the product.
 - c. If the product has been exposed to rain or water.
 - d. If the product does not operate normally,when the operating instructions are followed.Adjust only those controls that are covered by the operating instructions since improper adjustment of other controls may result in damage and will often require extension work by a qualified technician to restore the product to normal operation.
 - e. If the product has been dropped or the cabinet has been damaged.
 - f. If the product exhibits a distinct change in performance,indicating a need for service.

For Model 786PF

WARNING : This product included critical components which are essential for X-Radiation safety.

See service manual for proper replacement. Maximum 2nd anode voltage must not exceed 30KV at any operating conditions.

To measure 2nd voltage use high impedance meter connect (-) chassis, use a high voltage lead from (+) to 2nd anode.

VR501, VR601 has been sealed against improper replacement or defeating the control. Instructions for proper replacement of such sealed controls should also be provided in the service information.

B. SPECIFICATIONS

786PF

1. Screen	17" 0.25mm dot pitch,Pure Flat Square Tube,90°deflection, Anti-glare,Anti-static,Anti-reflection.	
2. Visible Image Area	16.0 inch	
3. Active Display Area	310mm (H) × 230mm (V)	
4. Synchronization Range		
Horizontal	30 – 86 KHz	
Vertical	50 – 160 Hz	
5. Power Source	100 – 240 Vac , 60/50 Hz	
6. Power Consumption	120W (max.)	
7. Input Signal		
Video	Analog R.G.B. , 0.7Vp-p / 75 Ohm	
Sync.	TTL level,positive or negative polarity	
8. Connection Type	15 Pin D Type	
9. Resolution	1600 × 1200 pixels	
10. Color Temperature	9300°K / 6500°K	
11. Dimension (W×H×D)	410 × 418 × 423 (mm)	
12. Monitor Weight	16.8Kg (37.0Lbs)	
13. Base Operation		
Tilt	- 5° / + 15°	
Swivel	- 45° / + 45°	
14. Power Saving		
ON	< 120W	
OFF	< 5W	
15. Signal Connector Pin Assignment		
Pin No.		
1. Red	6. Red Ground	11. Ground
2. Green	7. Green Ground	12. SDA
3. Blue	8. Blue Ground	13. Horizontal Sync.
4. Ground	9. Not Connected	14. Vertical Sync.
5. Self Test	10. Sync. Ground	15. SCL

C. TIMING CHART



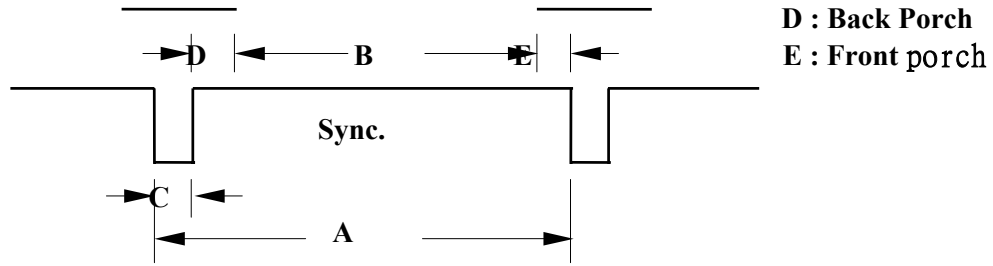

Preset Modes	VGA 640 x 480	VGA 720 x 400	VESA 800 x 600	VESA 640 x 480	XGA 1024 x 768	SIEMENS 640 x 480	VESA 800 x 600	VESA 1024 x 768	SIEMENS 800 x 600	VESA 1024 x 768	VESA 1280 x 1024
Dot Rate (MHz)	25.175	28.322	40.000	36.000	65.000	40.500	56.25	78.750	67.5	94.5	135
F.H (KHz)	31.469	31.469	37.879	43.269	48.363	50.600	53.674	60.023	63.92	68.677	79.976
A- Period (uS)	31.778	31.778	26.400	23.111	20.677	19.752	18.631	16.660	15.644	14.561	12.504
B- Active (uS)	25.422	25.422	20.000	17.778	15.754	15.802	14.222	13.003	11.852	10.836	9.481
C- Sync (uS)	3.813	3.813	3.200	1.556	2.092	1.58	1.138	1.219	0.948	1.016	1.067
D-Back Porch (uS)	1.907	1.907	2.200	2.222	2.462	1.975	2.702	2.235	2.370	2.201	1.837
E-Front Porch (uS)	0.318	0.318	1.000	1.556	0.369	0.395	0.569	0.203	0.474	0.508	0.119
F . V (Hz)	59.941	70.087	60.317	85.0	60.004	100.1	85.061	75.029	100.0	84.997	75.025
A- Period (Ms)	16.683	14.268	16.579	11.764	16.666	9.995	11.756	13.328	9.997	11.765	13.329
B- Active (mS)	15.253	12.711	15.840	11.093	15.880	9.481	11.179	12.795	9.387	11.183	12.804
C- Sync (mS)	0.064	0.064	0.106	0.069	0.124	0.059	0.056	0.050	0.047	0.044	0.038
D-Back Porch (mS)	1.049	1.112	0.607	0.578	0.600	0.435	0.503	0.466	0.548	0.524	0.475
E-Front Porch (mS)	0.254	0.222	0.026	0.023	0.062	0.02	0.019	0.017	0.016	0.015	0.013
H/V SYNC	- . -	- . +	- . -	+ . +	- . -	- . -	+ . +	+ . +	+ . +	+ . +	+ . +
Interlaced	NON	NON	NON	NON	NON	NON	NON	NON	NON	NON	NON

D. CONTROL LOCATION

Font control panel

- a. Power Switch
- b. Power Indicator
- c. Encoder
- d. Enhance Key

E. ADJUSTMENT CONTROL LOCATION

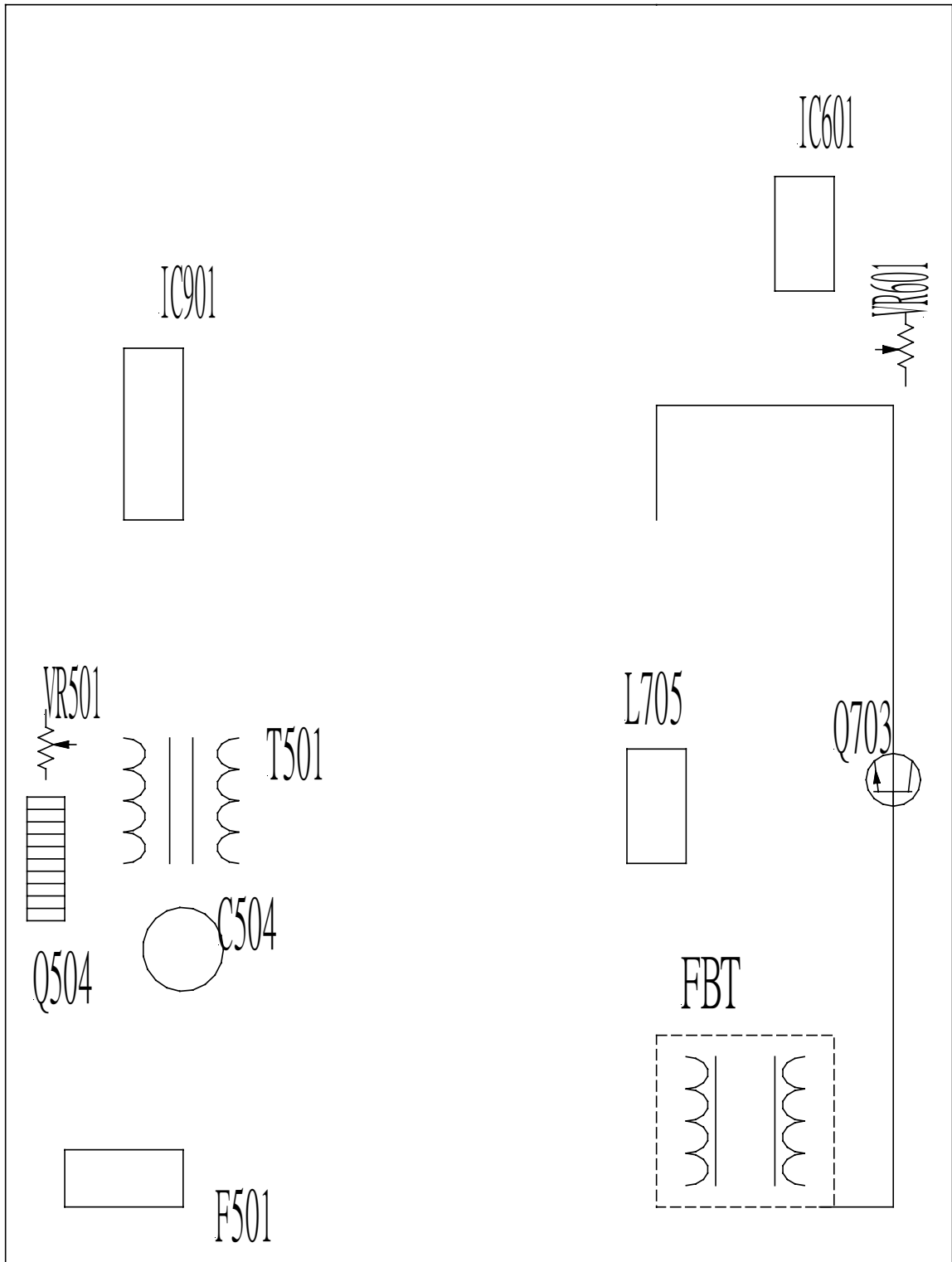

F. ADJUSTMENT PROCEDURE

ITEM Program Menu.	# Test Meter * Test Point @ Pattern	Operation	Adjusting Value
-----------------------	---	-----------	-----------------

A	B+ Adjust	# Digital Voltmeter * D510 Negative @ Crosshatch Pattern (31.5KHz,640x480)	1. Make the adjustment to the value shown at right by turning the VR501 on the main PCB.	15.5V ±0.2V
B	High Voltage Adjust	# Digital Voltmeter # High Voltage Probe * Anode Cap-GND @ Crosshatch Pattern (31.5KHz,640x480)	1. Turn the power switch of the monitor OFF . 2. Connect high voltage probe to Anode Cap and GND. 3. Turn the power switch of the monitor ON . (15 minutes) 4. Make the adjustment to the value shown at right by turning the VR601 on the main PCB.	26.0KV
C	Preset Adjust	@ Crosshatch (31.5KHz,640x480)	1. Turn the power switch of the monitor OFF . 2. Hold encorder key,then turn the power switch of the monitor ON . 3. Turn encorder key,make sure into preset picture, if not ,please return 1-2. 4. Please following the procedure of selection and adjusting an item using the OSD system as below steps for main function adjusent. Step 1 : Press and relese the OSD control knob to activate the OSD menu. Step 2 : Turn the knob to highlight the desired option of OSD icon. Step 3 : Press and release the knob again to access the option. The color of the inner area of the OSD will changed from blue to green. Step 4 : To make your adjustment,turn the knob Clockwise to increase or countclockwise to decrease the setting. Step 5 : Press and release the knob again to store the change.the color of the inner area will go back to blue.You can select EXIT icon and press the knob the exit the OSD menu.	Contrast : MAX. Brightness MAX. H-Size : 310mm V-Size : 230mm H-Posi. : Center V-Posi : Center
Program Menu.	ITEM # Test Meter * Test Point @ Pattern	Operation	Adjusting Value	

D	Background White Balance Adjust	# Color Analyzer @ R.G.B off (68KHz,1024x768)	<ol style="list-style-type: none"> 1. Set the contrast to MAX.,Brightness to Y=0.7 set color is 9300°K using the OSD. 2. Set the OSD to COLOR of sub menu and press knob. 3. Make the adjustment R.G.B BIAS low light to the value shown at right by using encorder. 	Y = 0.7 ±0.1FL x = 0.283 ±0.01 y = 0.297 ±0.01
E	White Balance Adjust	# Color Analyzer # Oscilloscope * Cathode G @ 3" block (68KHz,1024x768)	<ol style="list-style-type: none"> 1. Move the OSD to the R.G.B. DRIVE. 2. Move the OSD to the G DRIVE and make the adjustment to the value shown at right by using encorder. 3. Move the OSD to the R,B-DRIVE and make the Adjustment to the value shown at right by using Encorder. 	37VP-P x = 0.283 ±0.01 y = 0.297 ±0.01
F	ABL Adjust	# Color Analyzer @ Full White (64KHz,1280x1024)	<ol style="list-style-type: none"> 1. Set the contrast to MAX.,Brightness to MAX. 2. Make the adjustment to the value shown at right by adjustment ABL on the OSD menu. 	Y = 33FL
G	Other Function Setting	@ Full White (64KHz,1280x1024)	<ol style="list-style-type: none"> 1. Set the FREQ. to 87 2. Set the OSD to MAG 3. Set the BURN to Disable 4. Set the TIME to 15 5. Set the DEFO to TDA9113/9112 	
H	Dynamic Focus Adjust	# Oscilloscope * FBT Pin14 @ Full White (31.5KHz,640x480)	<ol style="list-style-type: none"> 1. Set the contrast to MAX.,and adjustment Brightness to the raster just appear. 2. Make the adjustment to the value shown at right by adjust the VF on the OSD menu. 3. Make the check to the value shown at right by adjust the HF on the OSD menu. 	VF : 140 ±10VP-P HF : 430 ±10VP-P
I	Purity Adjust	@ Magenta color (31.5KHz,640x480)	<ol style="list-style-type: none"> 1. Adjust the purity magnet is in magneta color. 2. Turning two overlapping pawels in opposite directions. 3. Move them until they are at the same angle, 9 o'clock and 3 o'clock respectively. 	

ITEM Program Menu.	# Test Meter * Test Point @ Pattern	Operation	Adjusting Value
-----------------------	---	-----------	-----------------

J	Static Convergence Adjust	@ Magenta color (31.5KHz,640x480)	<ol style="list-style-type: none"> 1. Open the two pawels of the 4 pole magnets to allow the red and blue vertical lines to unite. 2. Open and rotate the two pawels at a contrast angle so that the red and blue horizontal lines can unite. 3. If the vertical lines deviates,open the two powals at the deviation position and make a monitor adjustment by changing its angle. 4. Display white crosshatch pattern. 5. Make the red and blue vertical lines at the center unite with the green by opening the two 6 pole pawels. 6. Rotate the two pawels at contrast angle so that the red and blue horizontal lines can unite with the green. 7. If the vertical lines deviate,change the angle of Pawels from the deviation position. 	
---	--	--------------------------------------	---	--

ADJUSTMENT CONTROL LOCATION

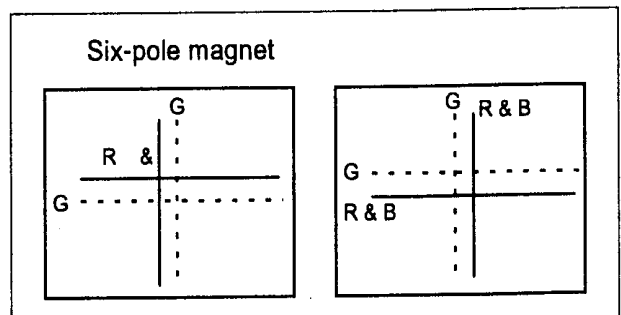
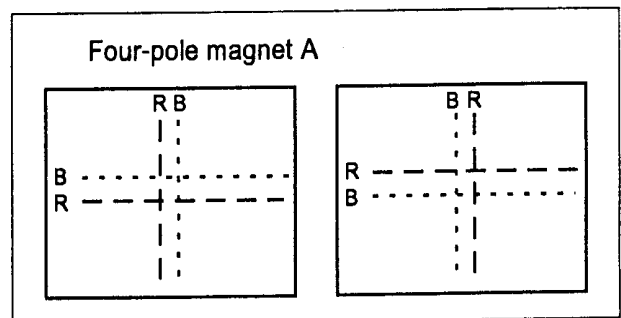
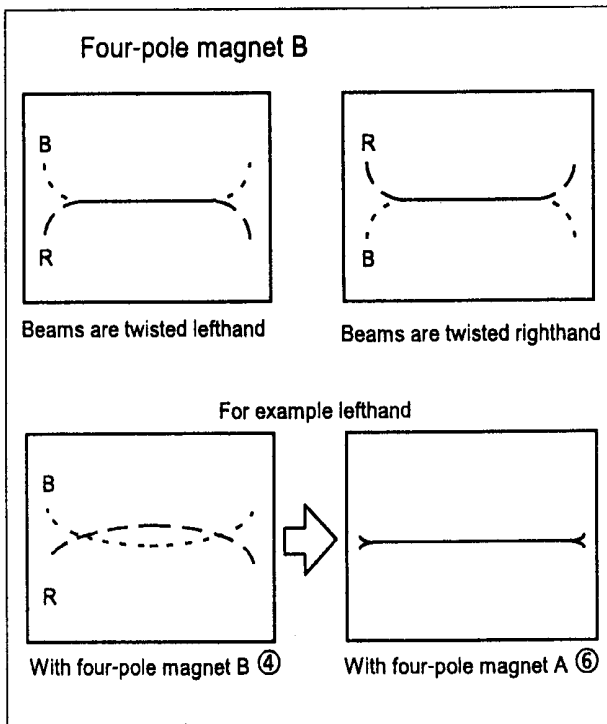
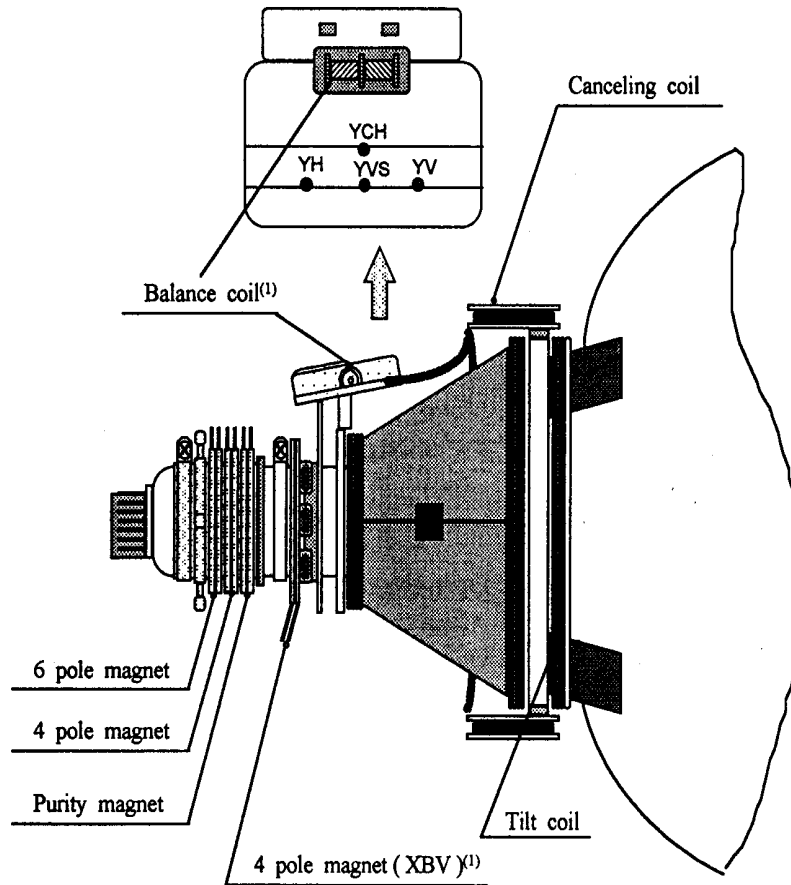

Convergence Adjusting Method

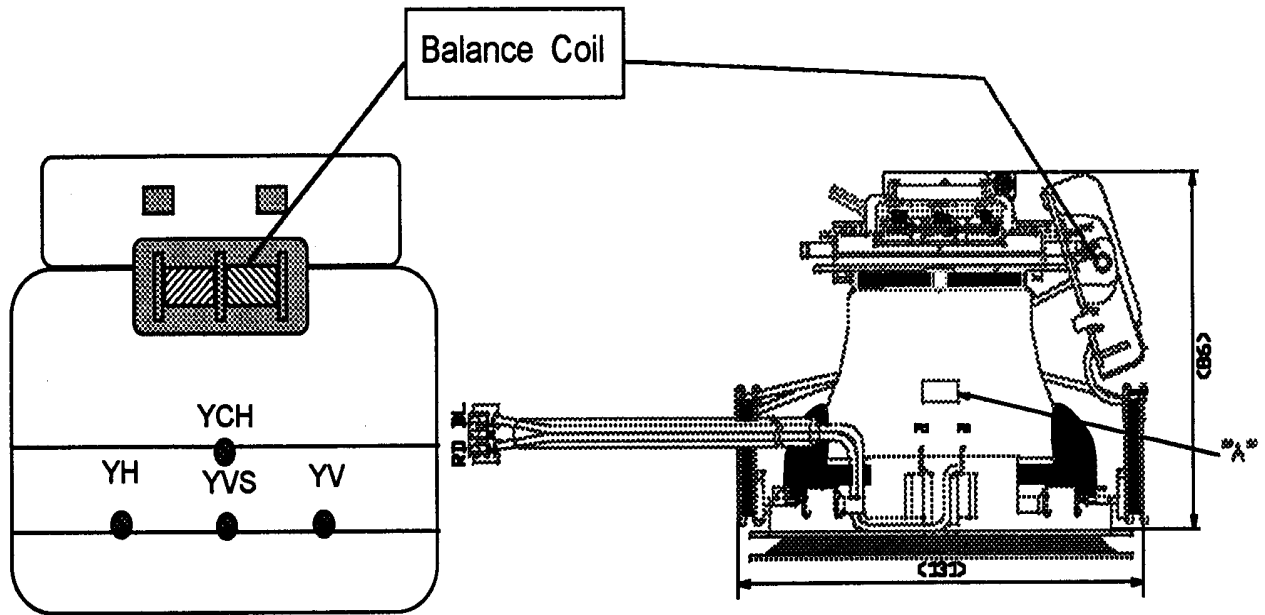

* YCH : YCH Adjusting

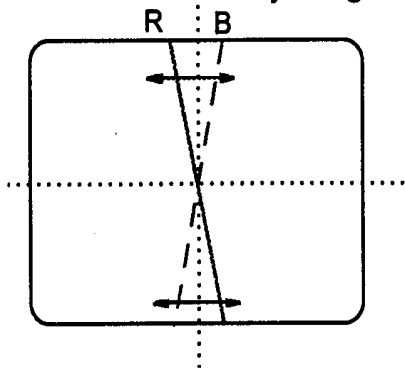

* Balance Coil : XCV Adjusting

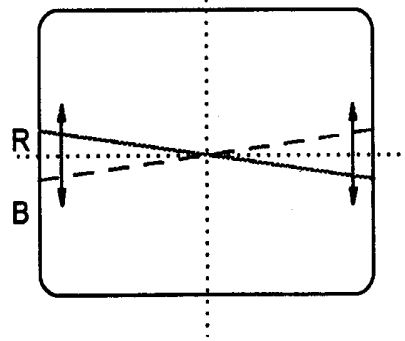

* YH : YBH Adjusting

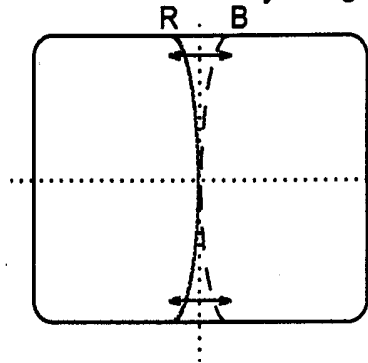

* YVS : YVS Adjusting

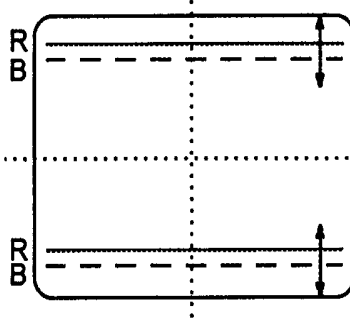

* YV : Tilt Adjusting

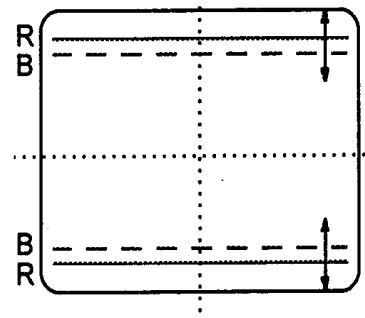

G. BLOCK DIAGRAM

SHEET 1 / POWER SUPPLY

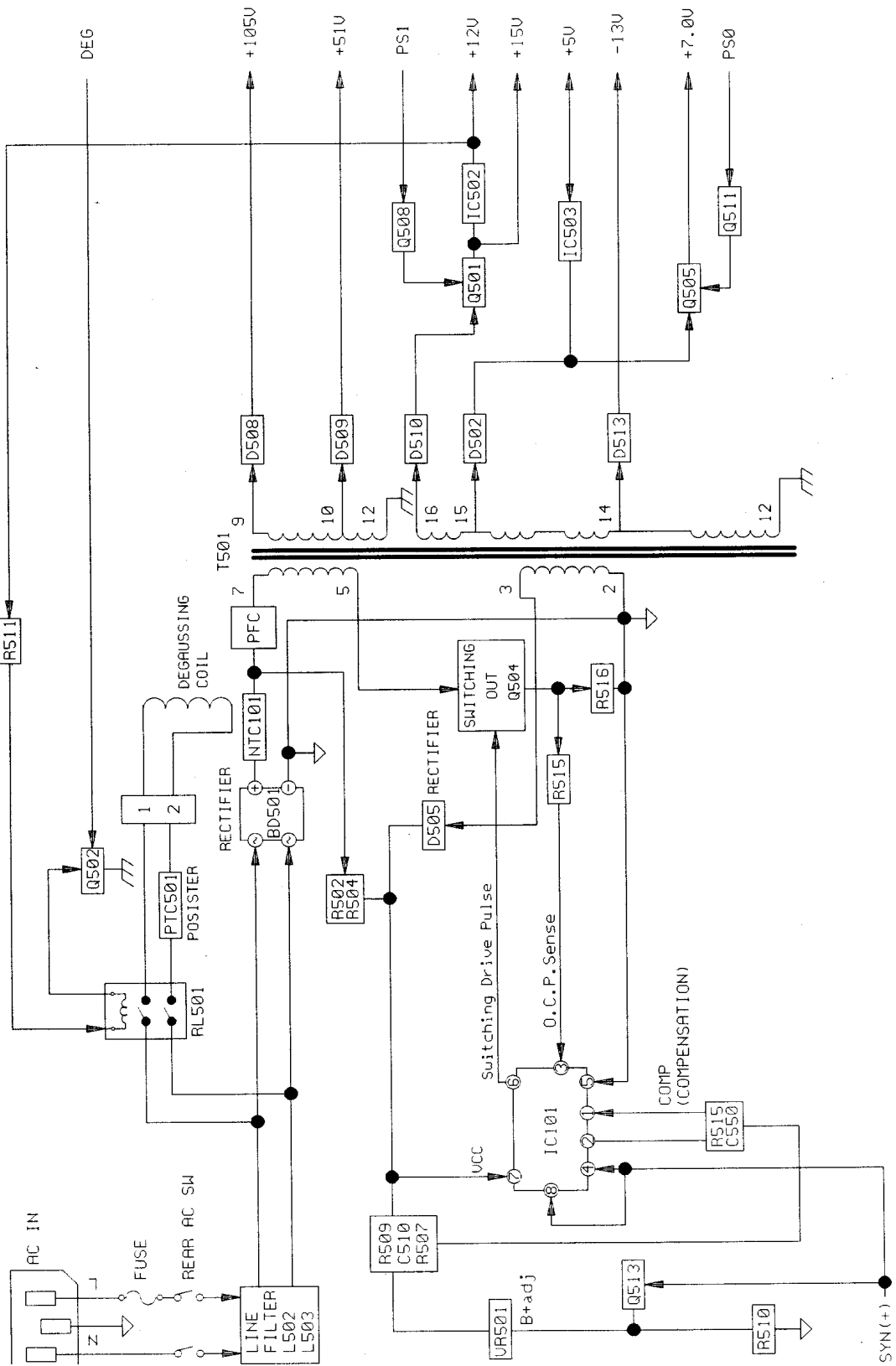

SHEET 2 H/V CONTROL/V OUT/TILT CONTROL

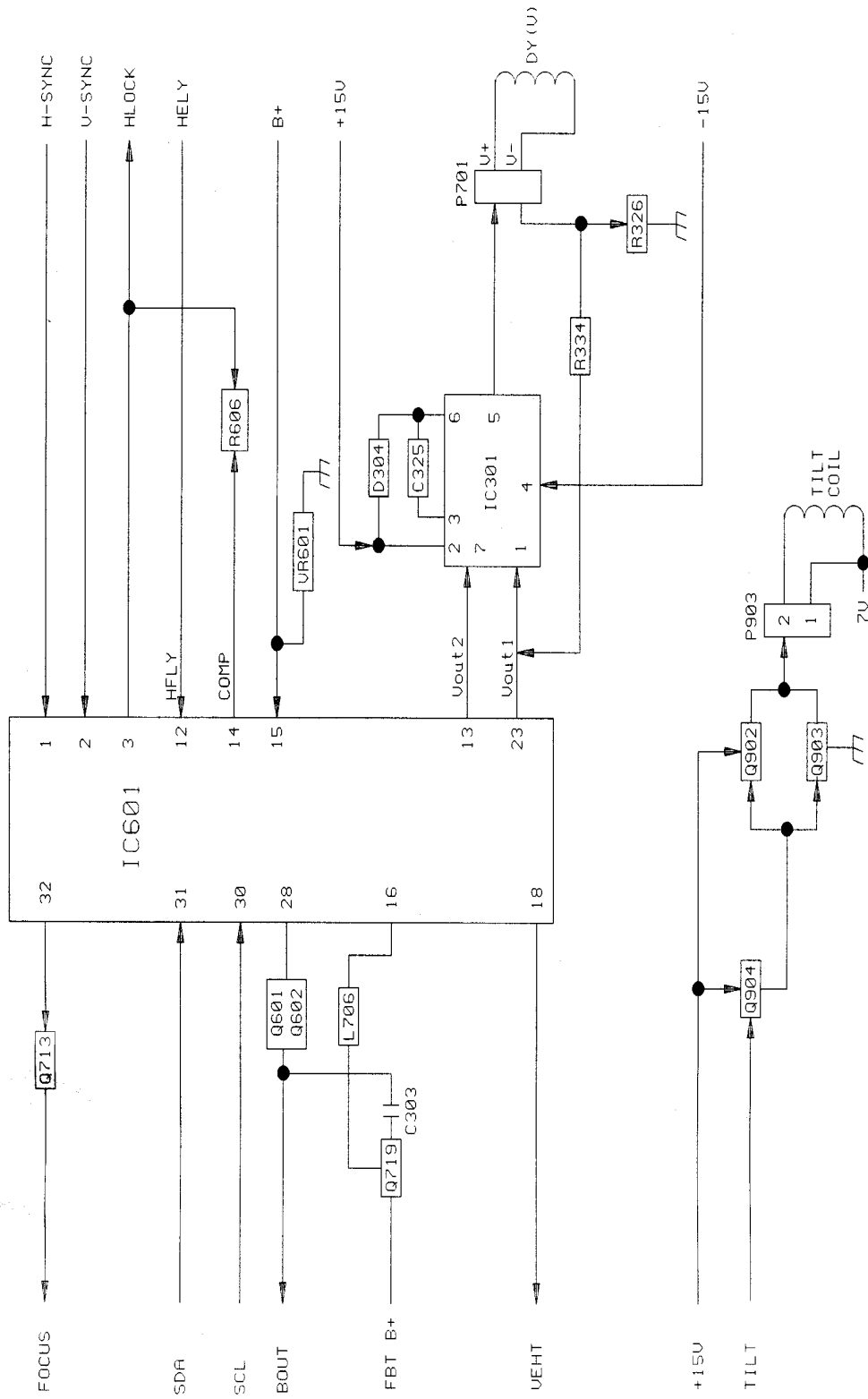

SHEET 4 EHT OUT / DYNAMIC FOCUS

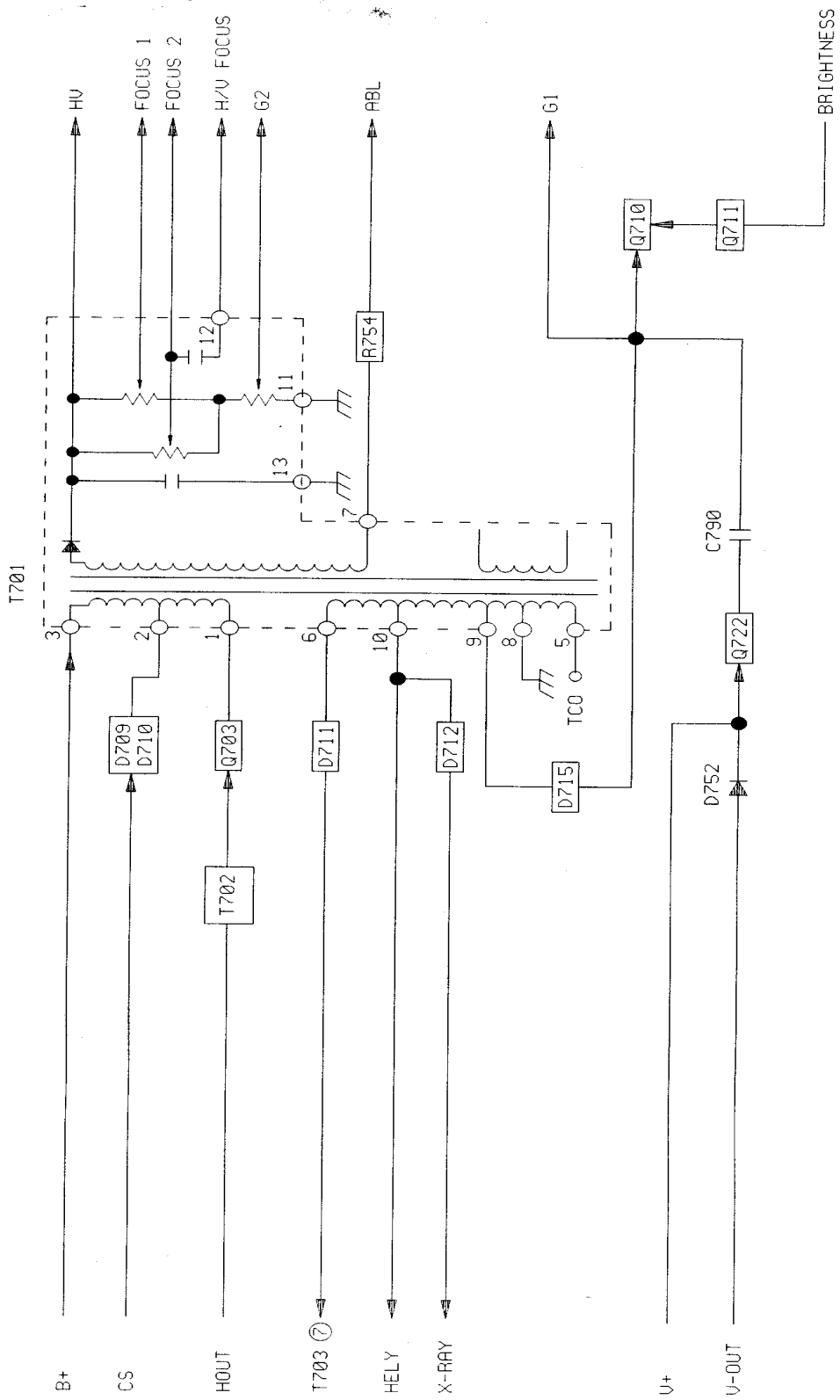

SHEET 5 MICON CONTROLLER

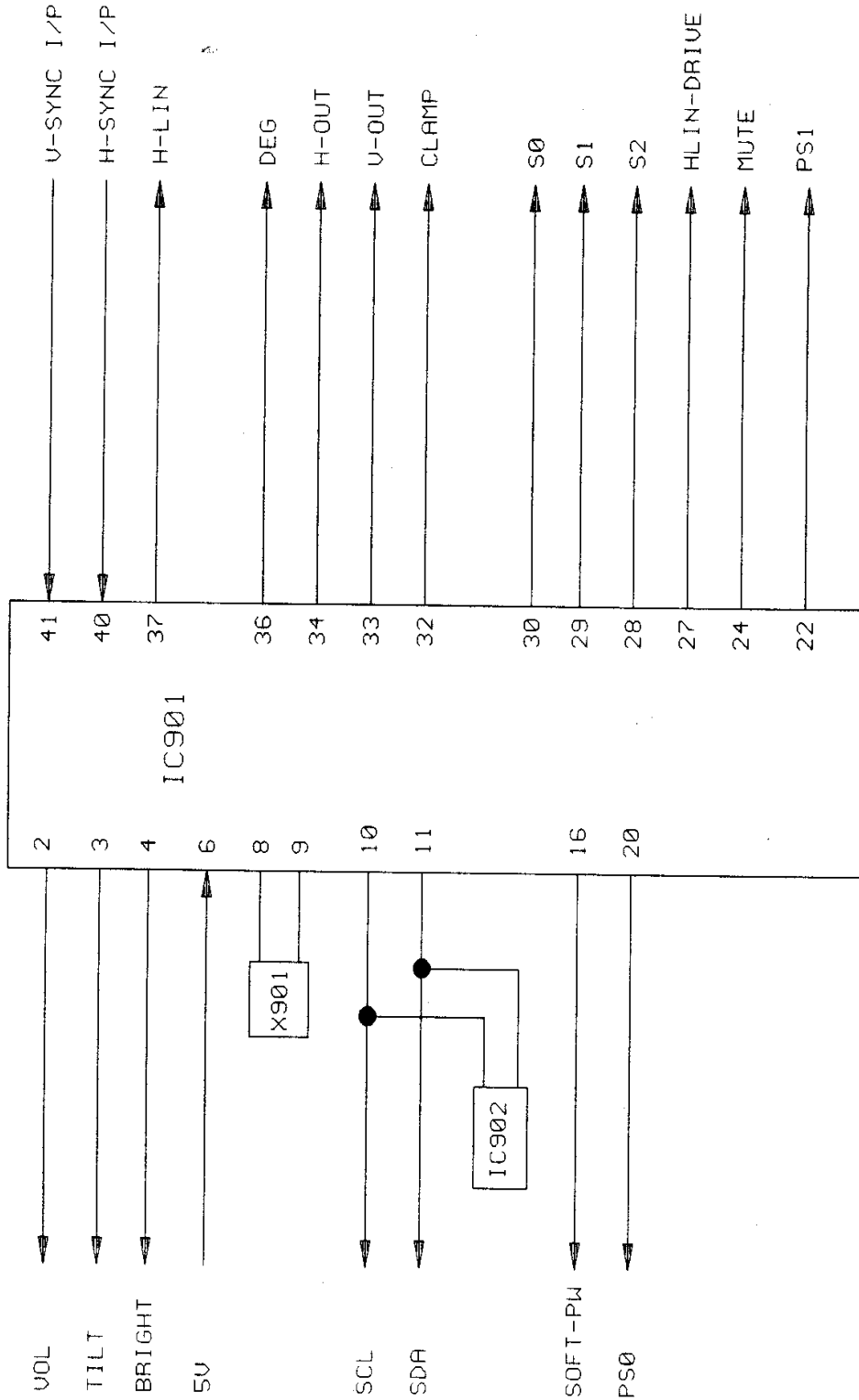

SHEET 6 VIDEO

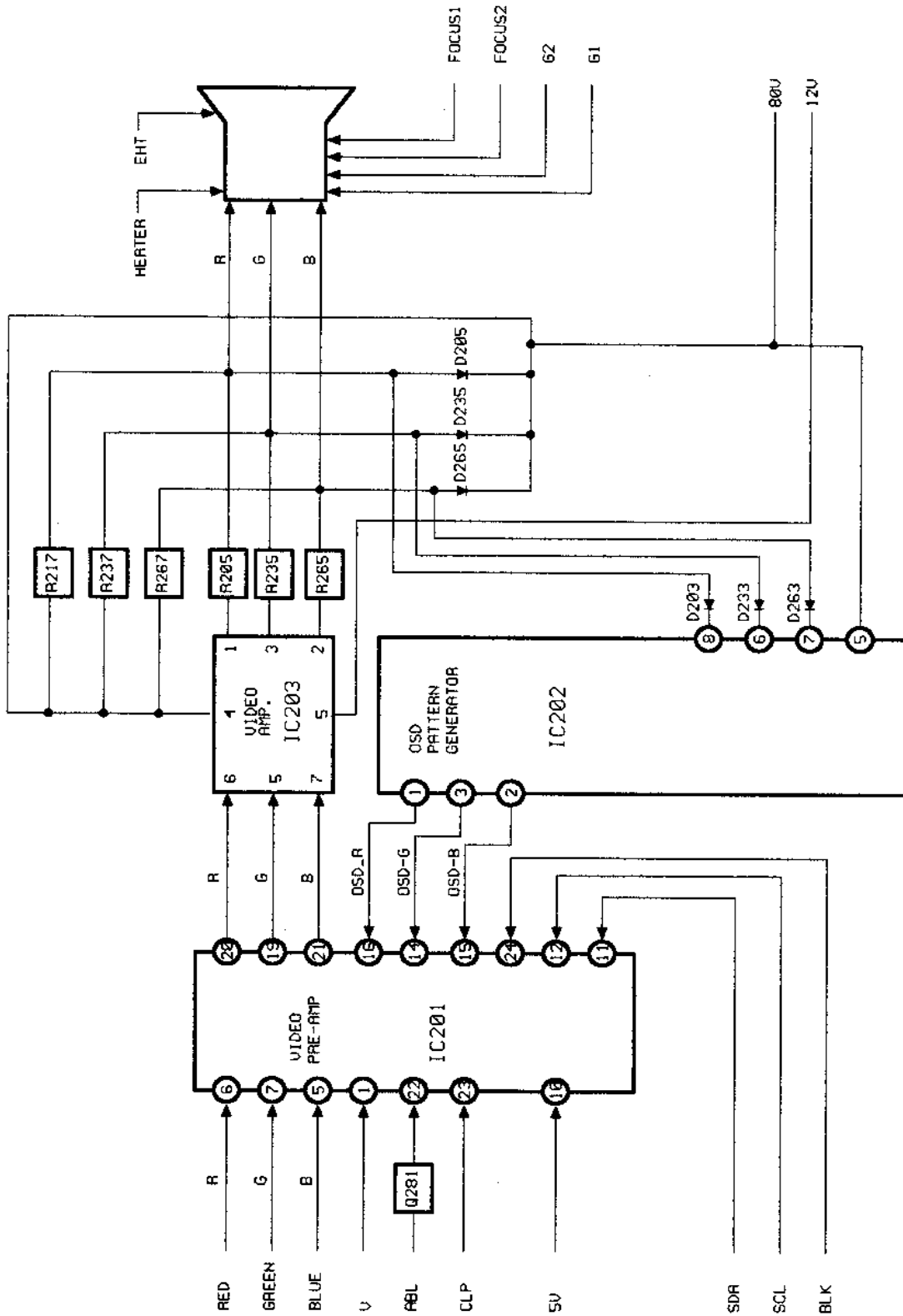

**BRIGHT HOR. LINE
APPEAR ON THE
SCREEN**

NO POWER

TRUBLE SHOOTING HINTS

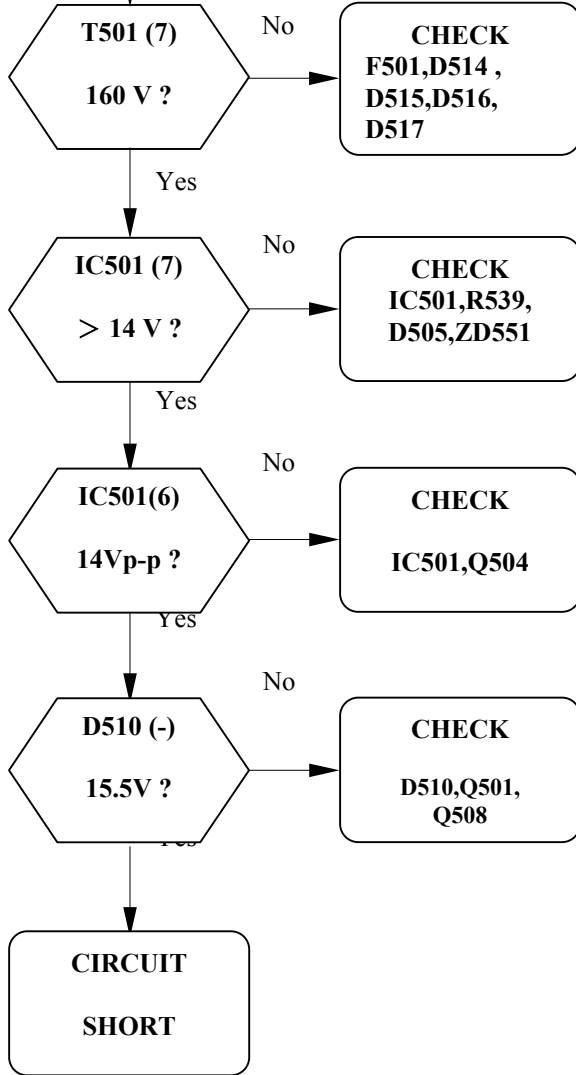

T501(7) VOLTAGE

AC120V IN	160V
AC220V IN	294V
AC230V IN	308V

**NO
RASTER**

No

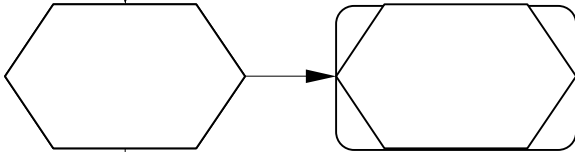

No

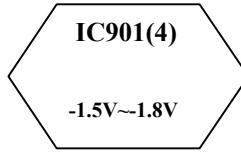

**CHECK
IC901
Surrounding
CKT**

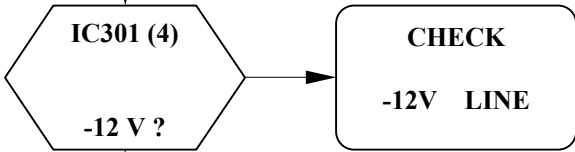

No

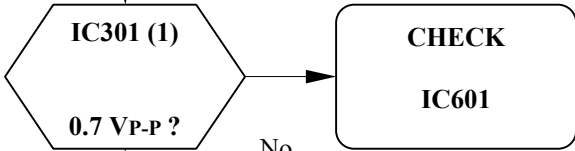

No

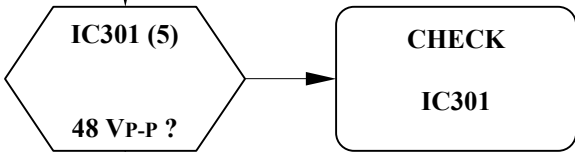

**CHECK
CRT DY**

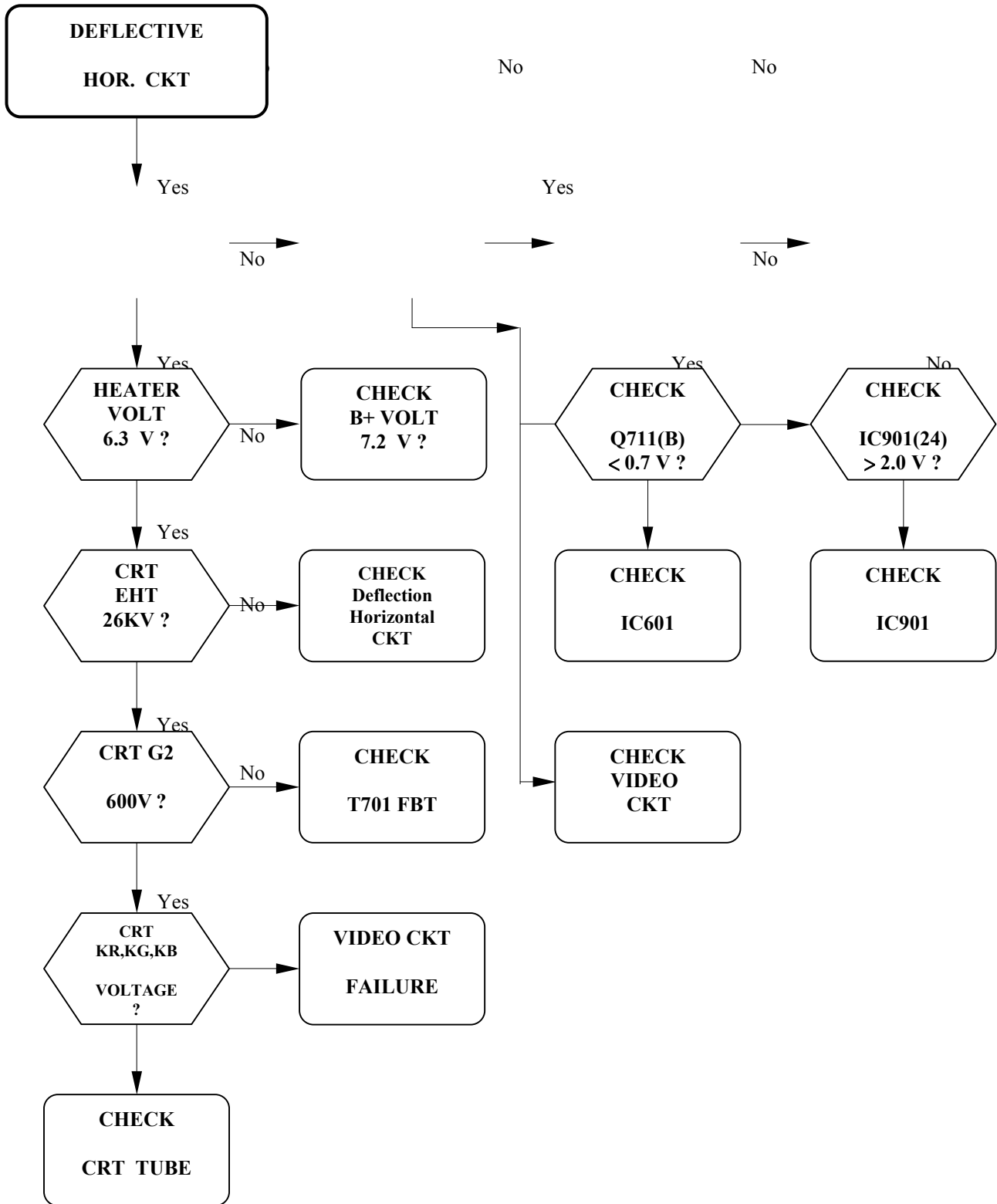

**OFF MODE
FAILURE**

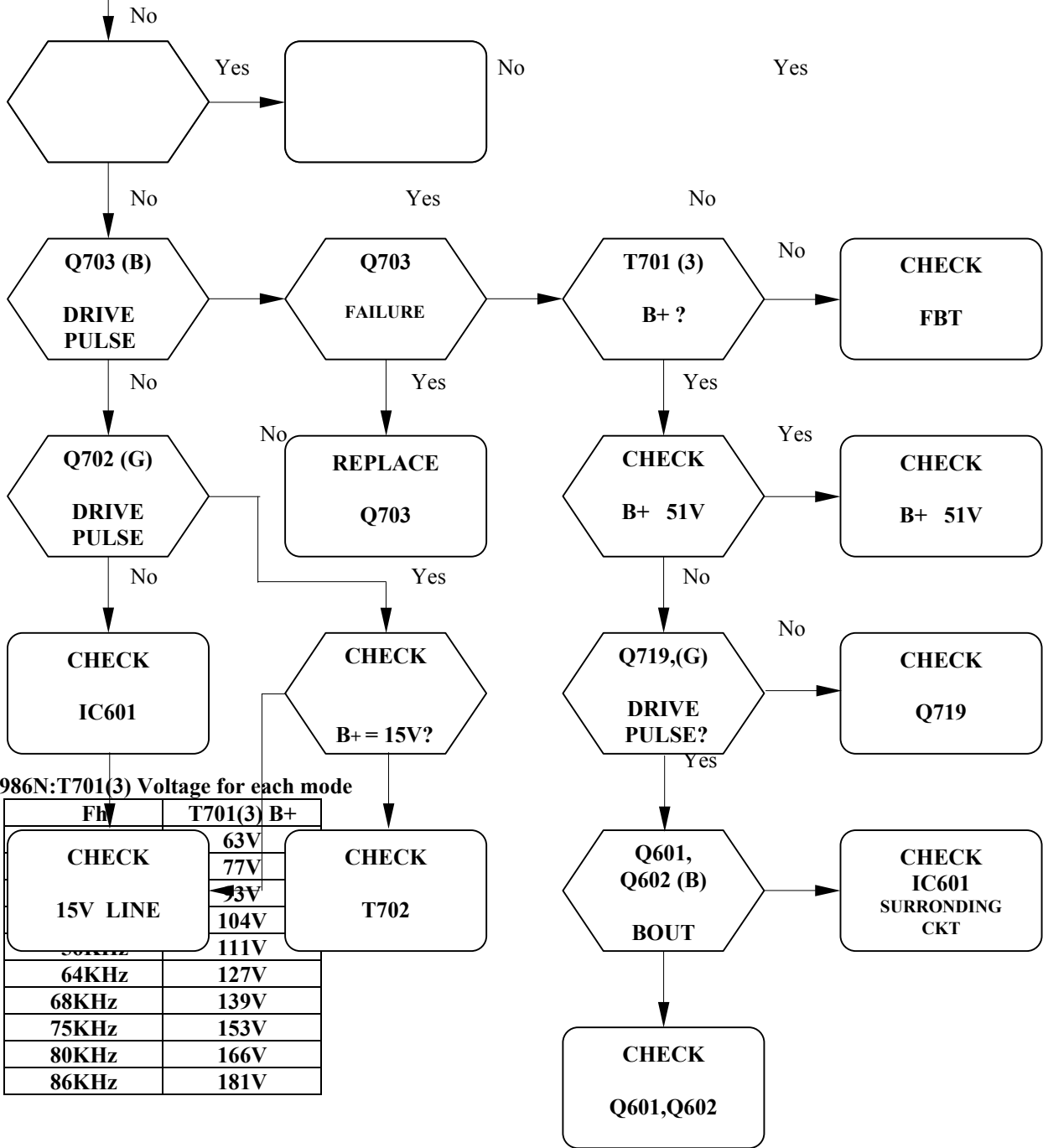

986N:T701(3) Voltage for each mode

FH	T701(3) B+
	63V
	77V
	93V
	104V
	111V
64KHz	127V
68KHz	139V
75KHz	153V
80KHz	166V
86KHz	181V

VESA STANDARD DPMS

ITEM MODE	H/V Sync.	VIDEO	LED GREEN
NORMAL	ON/ON	NORMAL	ON
STAND BY	OFF/ON	OFF	FLICKER
SUSPEND	ON/OFF	OFF	FLICKER

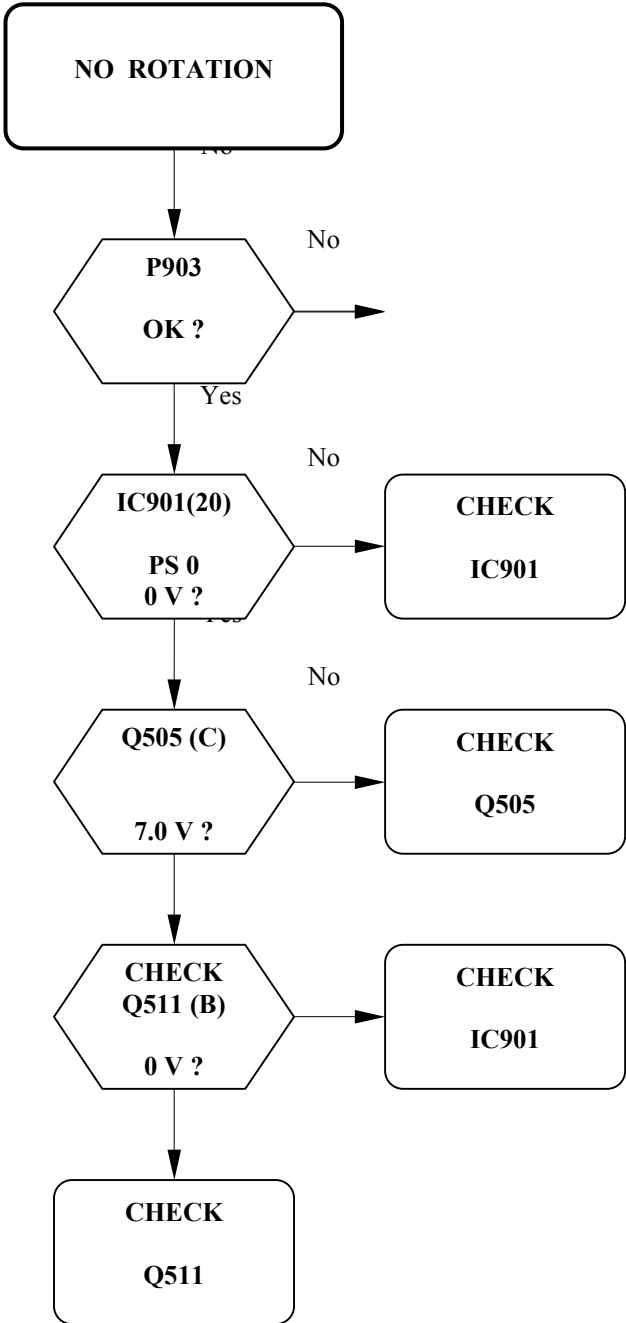

No

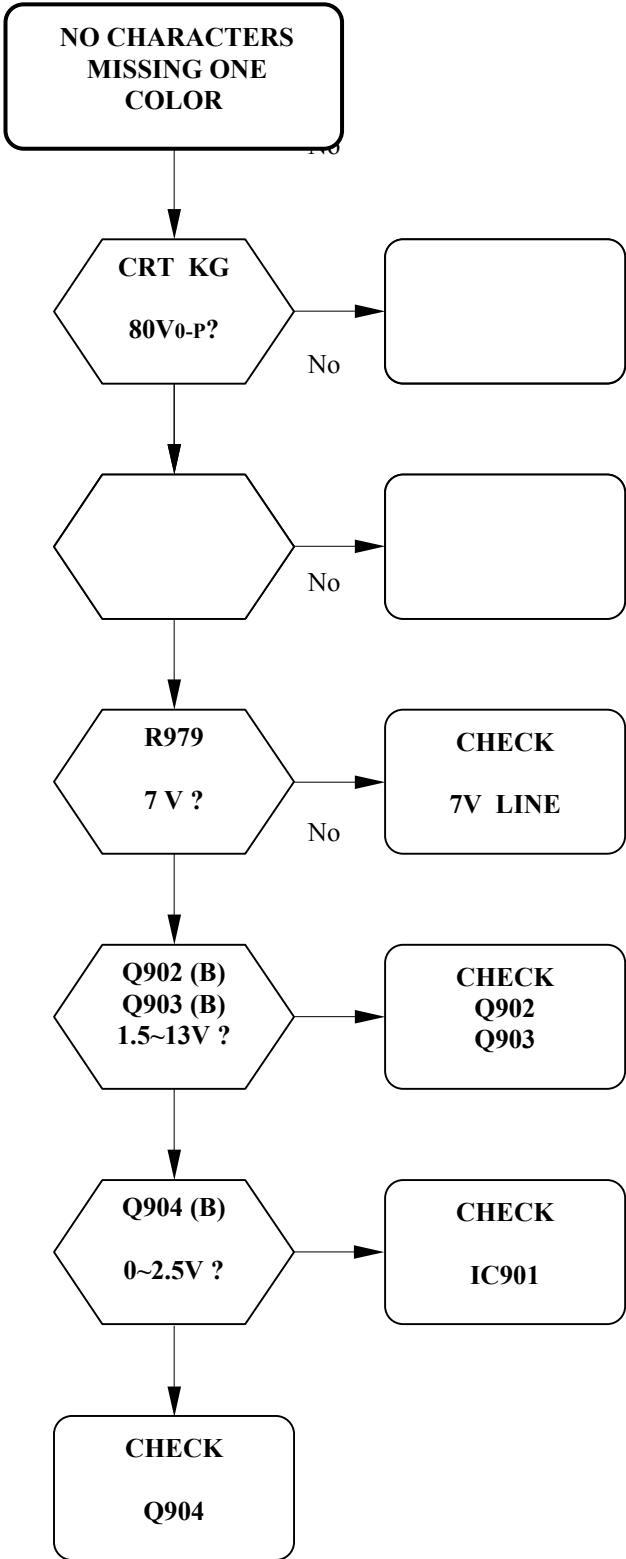

Example:Missing Green

No

Yes

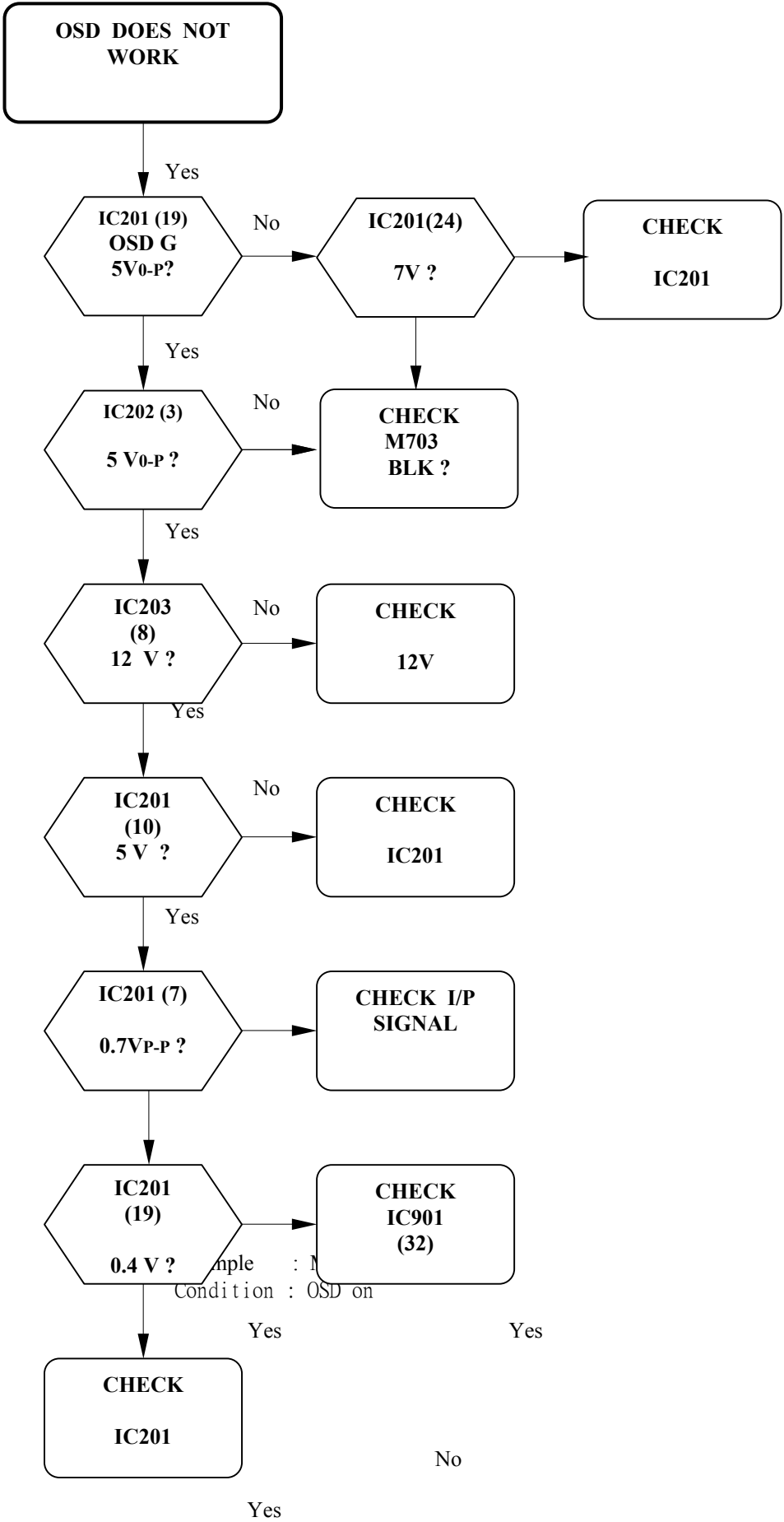

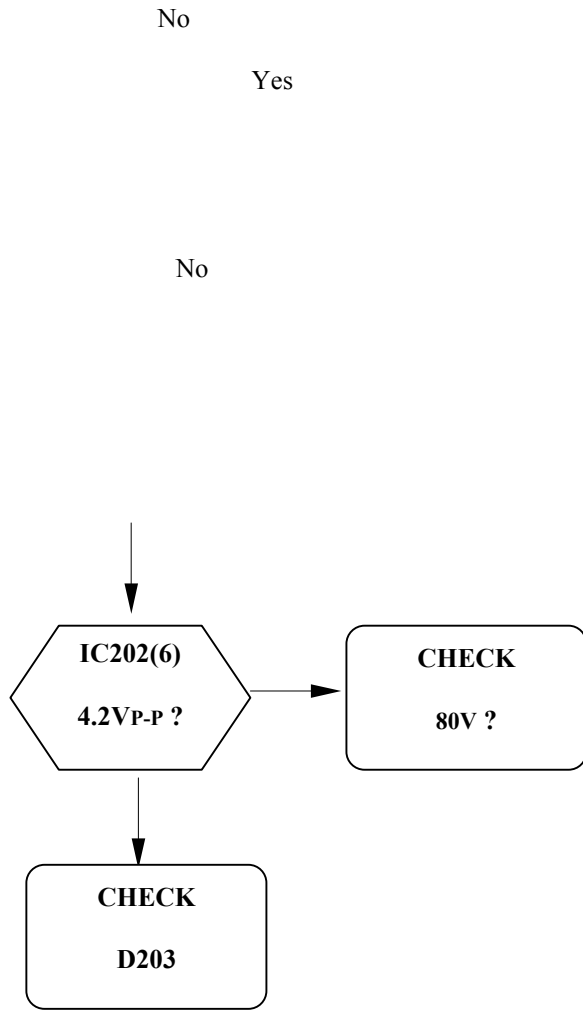

I. REPLACEMENT PARTS LIST

786PF

Spare Parts List

REV:A

Location.	Parts Number	Parts Description	Q'ty
R631	210-100-0256	10Ω 1/2W	1
R734	210-100-0256	10Ω 1/2W	1
R762	210-100-0456	10Ω 1/4W	1
R7A2	210-100-0856	10Ω 1/8W	1
R612,611,663,912,918,926,927,976 R977	210-101-0456	100Ω 1/4W	9

R205,235,265,281,284,285,516,664 R711A,918A,942,943,952,953,982 R984,985	210-101-0856	100 Ω	1/8W	17
R703	210-101-0856	100 Ω	1/8W	1
R736	210-102-0256	1K Ω	1/2W	1
R525,740,754,7A8	210-102-0456	1K Ω	1/4W	4
R210,240,270,533,546,626,755,793 R974,993	210-102-0856	1K Ω	1/8W	10
R991	210-102-0856	1K Ω	1/8W	1
R529,536,610,983	210-103-0456	10K Ω	1/4W	4
R288,291,510,590, 606,615, 630, 651 R730,931,947	210-103-0856	10K Ω	1/8W	11
R710	210-203-0856	20K Ω	1/8W	1
R724	210-103-0856	10K Ω	1/8W	1
R797A	210-103-0856	10K Ω	1/8W	1
R2A3,770	210-104-0256	100K Ω	1/2W	2
R508,731	210-104-0456	100K Ω	1/4W	2
R725	210-104-0456	100K Ω	1/4W	1
R767	210-104-0856	100K Ω	1/8W	1
R757	210-105-0456	1M Ω	1/4W	1
R745	210-112-0856	1.1K Ω	1/8W	1
R737	210-134-0456	130K Ω	1/4W	1
R929	210-683-0456	68K Ω	1/4W	1
R303	210-123-0456	12K Ω	1/4W	1
R666	210-223-0856	22K Ω	1/8W	1
R768	210-133-0856	13K Ω	1/8W	1
R761	210-272-0456	2.7K Ω	1/4W	1
R602	210-153-0456	15K Ω	1/4W	1
R608	210-153-0856	15K Ω	1/8W	1
R515,589	210-154-0856	150K Ω	1/8W	2
R614	210-182-0856	1.8K Ω	1/8W	1
R797A	210-183-0856	18K Ω	1/8W	1
R914	210-203-0456	20K Ω	1/4W	1
R629	210-203-0856	20K Ω	1/8W	1
R307,732	210-2R2-0456	2.2 Ω	1/4W	2
R2A7	210-220-0456	22 Ω	1/4W	1
R207,237,267,	210-221-0256	220 Ω	1/2W	3
R534	210-221-0456	220 Ω	1/4W	1
R205,235.265,910,911	210-221-0856	220 Ω	1/8W	5
R741	210-222-0856	2.2K Ω	1/8W	1

R706,708	210-222-0856	2.2K Ω	1/8W	2
R535,654,728	210-223-0856	22K Ω	1/8W	3
R667	210-223-0856	22K Ω	1/8W	1
R723	210-223-0856	22K Ω	1/8W	1
R717	210-223-0856	22K Ω	1/8W	1
R794A	210-245-0856	2.4M Ω	1/8W	1
R308	210-471-0256	470 Ω	1/2W	1
R521,713	210-271-0456	270 Ω	1/4W	2
R670,7A1	210-302-0856	3.0K Ω	1/8W	2
R514	210-303-0456	30K Ω	1/4W	1
R979	210-330-0456	33 Ω	1/4W	1
R7A6	210-331-0856	330 Ω	1/8W	1
R601,665	210-332-0856	3.3K Ω	1/8W	2
R604	210-332-0856	3.3K Ω	1/8W	1
R707	210-332-0856	3.3K Ω	1/8W	1
R603	210-333-0456	33K Ω	1/4W	1
R588	210-333-0856	33K Ω	1/8W	1
R7A7	210-334-0256	330K Ω	1/2W	1
R733	210-334-0456	330K Ω	1/4W	1
R207,237,267	210-334-0856	330K Ω	1/8W	1
R724,730	210-363-0856	36K Ω	1/8W	2
R544	210-363-0456	36K Ω	1/4W	1
R287	210-390-0256	39 Ω	1/2W	1
R765	210-392-0856	3.9K Ω	1/8W	1
R7A3,928	210-393-0856	39K Ω	1/8W	2
R615	210-103-0856	10K Ω	1/8W	1
R588	210-433-0856	43K Ω	1/8W	1
R712	210-4R7-0456	4.7 Ω	1/4W	1
R202,232,262,551,726,729 L200,L230,L260	210-470-0856	47 Ω	1/8W	9
R726	210-470-0856	47 Ω	1/8W	1
R908	210-471-0456	470 Ω	1/4W	1
R771	210-471-0856	470 Ω	1/8W	1
R509,532,617,618, 903	210-472-0456	4.7K Ω	1/4W	5
R980	210-472-0456	4.7K Ω	1/4W	1
R901	210-472-0456 622-10a-9101	4.7K Ω Jumper	1/4W	1
R283,2A8,620,653,727,741,933,934, R975,989,994	210-472-0856	4.7K Ω	1/8W	11
R718	210-472-0856	4.7K Ω	1/8W	1
R992,716,722,722A	210-472-0856	4.7K Ω	1/8W	1

R619,669	210-473-0456	47K Ω	1/4W	2
R290,507,522,622,932,940,941,	210-473-0856	47K Ω	1/8W	7
R501	210-474-0256	470K	1/2W	1
R206,236,266,2A2	210-510-0256	51 Ω	1/2W	4
R739,760	210-512-0856	5.1K Ω	1/8W	2
R2A6	210-513-0856	51K Ω	1/8W	1
R905	210-561-0456	560 Ω	1/4W	1
R920	210-561-0856	560 Ω	1/8W	1
R334	210-562-0456	5.6K Ω	1/4W	1
R290.292.294.295	210-562-0856	5.6K Ω	1/8W	4
R604	210-562-0856	5.6K Ω	1/8W	1
R668	210-563-0456	56K Ω	1/4W	1
R292	210-622-0856	6.2K Ω	1/8W	1
R738	210-562-0856	5.6K Ω	1/8W	1
R520	210-6R8-0456	6.8 Ω	1/4W	1
R791	210-682-0856	6.8K Ω	1/8W	1
R746	210-682-0856	6.8K Ω	1/8W	1
R588	210-683-0856	68K Ω	1/8W	1
R744	210-683-0856	68K Ω	1/8W	1
R201.231.261	210-750-0856	75 Ω	1/8W	3
R981	210-752-0456	7.5K Ω	1/4W	1
R652	210-822-0856	8.2K Ω	1/8W	1
R766	210-682-0856	6.8K Ω	1/8W	1
R616	210-823-0856	82K Ω	1/8W	1
R605	210-823-0856	82K Ω	1/8W	1
R539	210-9R1-0256	9.1 Ω	1/8W	1
R703A	213-1R0-1059	1.0 Ω	R-NF 1W	1
R2A1	213-2R2-1059	2.2 Ω	R-NF 1W	1
R2A4	213-7R5-1059	7.5 Ω	R-NF 1W	1
R758	213-102-2059	1K Ω	R-NF 2W	1
R326	213-R91-1055	0.91 Ω	R-MNF 1W	1
R502,504	213-823-2059	82K Ω	R-MNF 2W	2
R732	214-2R2-0259	2.2 Ω	R-FR 1/2W	1
RP901	216-472-0457	4.7K Ω	$\pm 5\%$ R-NW	1
NTC501	218-7R0-0871	7 Ω	8A NTC	1
PTC501	219-9R0-0171	9 Ω	PTC	1
R711	220-150-2059	15 Ω	R-MNF 2W	1
R704	220-331-2059	330 Ω	R-MNF 2W	1
R777	220-2R2-1059	2.2 Ω	R-MNF 1W	1

R513	220-2R7-3059	2.7Ω	R-MNF	3W	1
R714	220-R47-3059	0.47Ω	R-MNF	3W	1
R623	220-4R7-2059	4.7Ω	R-MNF	2W	1
R528	220-561-1059	560Ω	R-MNF	1W	1
R503	220-753-3059	75KΩ	R-MNF	3W	1
R705	220-8R2-2059	8.2Ω	R-MNF	2W	1
R609	221-081-1152	11.5KΩ	1%	1/8W	1
R749	221-081-2400	240Ω	1%	1/8W	1
R747	221-081-2702	27KΩ	1%	1/8W	1
R752	221-081-3003	300KΩ	1%	1/8W	1
R751	221-081-3003	300KΩ	1%	1/8W	1
R302	221-081-3572	35.7KΩ	1%	1/8W	1
R753	221-081-3242	32.4KΩ	1%	1/8W	1
R748	221-081-5101	5.1KΩ	1%	1/8W	1
R613	221-081-5621	5.62KΩ	1%	1/8W	1
R333	221-081-5761	5.76KΩ	1%	1/8W	1
R750	221-081-6190	619Ω	1%	1/8W	1
PTC502	222-040-7200T	Polyswitch	0.4A/72V		1
VR501,VR601	231-202-0677	2K,VR			2
R526	232-R22-2059	0.22Ω	R-WR	2W	1
R759	232-R30-3059	0.3Ω	R-WR	3W	1
C935,948	300-1R0-5020	1.0u	50V	E.C	2
C949	300-1R0-5020	1.0u	50V	E.C	1
C205,235,265	300-1R0-0122	1.0u	100V	E.C	3
C922	300-100-1620	10u	16V	E.C	1
C270,274,582,704,907	300-100-5020	10u	50V	E.C	5
C725	300-100-5020	10u	50V	E.C	1
C275,276,278	300-100-0120	10u	100V	E.C	3
C722	300-100-0423	10u	250V	E.C	1
C505,507,527,601	300-101-1623	100u	16V	E.C	4
C523	300-101-2520	100u	25V	E.C	1
C325,703	300-101-3520	100u	35V	E.C	2
C525	300-102-1623	1000u	16V	E.C	1
C323,520	300-102-2523	1000u	25V	E.C 105 C	1
C206,236,266	300-R22-0122	0.22u	100V	E.C	1
C716	300-2R2-0423-SL	2.2u	250V	E.C Lesr	1
C623,742	300-220-1620	22u	16V	E.C	2
C520	300-220-0222	22u	160V	E.C	1
C504	300-221-0522	220u	400V	E.C	1

C521	300-331-0123	330u	100V	E.C	105C	1
C510,612,613,715,774, 901	300-4R7-5020	4.7u	50V	E.C		6
C773	300-4R7-5020	4.7u	50V	E.C		1
C772	300-4R7-5020	4.7u	50V	E.C		1
C272,2A4,607,615	300-470-1620	47u	16V	E.C		4
C745	300-470-1620	47u	16V	E.C		1
C744	300-470-0120	47u	100V	E.C		1
C501,519,305	300-471-2520	470u	25V	E.C		3
C701	300-6R8-5020	6.8u	50V	E.C		1
R545	300-680-3520	68u	35V	E.C		1
C609	305-103-0550	0.01u	50V	PE		1
C292,626,627,628,629,905,906,914 C915,916,917	307-101-1170	100p	50V	C.C		11
C518,618A,771,740A	307-102-1160	1000p	50V	C.C		4
C2A2	307-102-3570	1000p	500V	C.C		1
C602,778,779	307-103-1170	0.01u	50V	C.C		3
C277,2A7,506,515,528,746,747	307-103-3570	0.01u	500V	C.C		7
C714	307-103-3570	0.01u	500V	C.C		1
C603,622	307-104-1770	0.1u	50V	10% C.C		2
C614	307-221-1170	220p	50V	10% C.C		1
C517,551,552,733	307-221-3570	220p	500V	C.C		4
C718	307-221-3570	220p	500V	C.C		1
C294	307-182-1170	1800p	50V	C.C		1
C550,625,705	307-222-1170	2200p	50V	C.C		3
C776	307-222-1170	2200p	50V	C.C		1
C726	307-222-3570	2200p	500V	C.C		1
C618	307-223-1170	0.022u	50V	C.C		1
C515	307-223-3570	0.022u	500V	C.C		1
C2A9	307-330-1170	33p	50V	C.C.		1
C509,751,752	307-331-1170	330p	50V	C.C.		3
C748,749,912,911	307-471-1170	470p	50V	10% C.C		4
C526,741	307-471-3570	470p	500V	10% C.C		2
C780	307-822-1170	8200p	50V	10% C.C		1
C2A3	307-472-6570	4700p	2KV	C.C		1
C583	307-561-1160	560p	50V	C.C.		1
C740	308-301-1152	300p	50V	C.C. NPO		1
C918,919	308-470-1150	47p	50V	C.C. NPO		2
C792	308-101-6860	100p	2KV	10% C.C		1
C732	309-102-1552	1000p	1.5KV	PHM		1
C713	309-332-1052	3300p	1KV	PHM		1

C712	309-432-1552	4300p 1.5KV	PHM	1
C620,790	310-104-0252	0.1u 250V	MEM	2
C710	310-823-0252	0.082u 250V	MPP	1
C716	310-225-0252-H	2.2u 250V	MPP	1
C717	310-224-0452	0.22u 400V	MPP	1
C709	310-274-0252	0.27u 250V	MPP	1
C731	310-824-0452	0.82u 250V	MPP	1
C508,524	315-224-2572	0.22u 250V	X-CAP	2
C502,503,555	317-222-4072	2200p 400V	Y-CAP	3
C619	318-102-0550	1000p 50V.	MEM	1
C611	318-103-0550	0.01u 50V.	MEM	1
C310,608,721	318-104-0550	0.1u 50V	MEM	3
C620,790	318-104-0250	0.1u 250V	MEM	2
C727	318-105-1052	1u 100V	MEM	1
C793	318-152-0152	1500p 100V.	MEM	1
C605	318-154-0550	0.15u 50V	MEM	1
C307	318-224-0550	0.22u 50V	MEM	1
C606	318-474-0550	0.47u 50V	MEM	1
C309	318-682-0550	6800p 50V 10%	MEM	1
C719,720	319-101-1060	100p 1KV	C.C	2
C522	319-221-1060	220p 1KV 10%	C.C	1
C516	326-222-0520	2200p 50V 2%	PL	1
C610	326-821-0520	820p 50V 2%	PL	1
C201,231,261,701	328-103-2260	0.01u 50V	C.C	4
C777	328-103-2260	0.01u 50V	C.C	1
C708,778	328-103-2260	0.01u 50V	C.C	2
C271,291,293,295,202,232,262,2A1, C2A5,2A6,603,622,616,513,903,904, C 908,909,920,921,902A,902B,724	328-104-2690	0.1u 50V	C.C	23
C702,730	328-104-2690	0.1u 50V	C.C	2
SW902,903	401-170-D200	Tact Switch		2
SW901	401-240-0501	Encoder		1
SW501	401-270-0402	Soft Power Switch		1
RL501	402-001-212DM	DSA-SS-212DM5 Relay		1
RL701	402-001-212DM5	DSA-SS-212DM5 Relay		1
JK302	409-003-0104A	Phone Jack 3Pin		1
JK301	409-003-0201A	DC Jack 3Pin		1
IC902 Socket	410-008-0102	IC902 Socket 8Pin		1
CRT SOCKET (17")	411-100-0006	CRT Socket		1
P501	412-600-0001	AC Inlet Socket		1

SG281	430-301-0001	300V	1
IC902	501-000-2408	AT24C08	1
IC901	503-100-62P2-P	CPU	1
IC201	504-550-1237	LM1237	1
IC202	504-000-2480	LM2480	1
IC203	504-000-2469	TDA2469	1
IC203 Heat Sink	123-003-P6SE-E	IC203 H.S	1
IC301	504-900-8172	TDA8172	1
IC301 Heat Sink	120-002-P6SE-B	IC301,H.S	1
Silicon Rubber	120-100-2001	For IC301	1
Shoulder Washers	540-500-2002C	For IC301	1
IC501	504-200-3842A	KA3842A	1
IC502	505-1R5-7812	LM7812 (TO-220)	1
IC503	505-093-76285	AMC76289 300mA/5V	1
IC601	504-700-9116	TDA9116	1
IC203	504-000-2469	LM2469	1
Q281,602,653,714,715,903	510-000-0733	2SA733	6
Q505	510-010-772SP	HSB772S (TO – 92)	1
Q502,508,511,513,601,606,651,708 Q711,722,902,904,907	510-023-0945	2SC945P	13
Q710	510-200-0423	BF423	1
Q702	511-001-2865	2SK2865	1
Q704, 725	510-023-0945	2SC945P	2
Q706	510-023-0945	2SC945P	1
Q726	510-023-0945-P	2SC945P	1
Q501	510-010-0772	HSB772 (TO – 126)	1
Q701	510-010-0772	HSB772 (TO – 126)	1
Q713	510-300-SA44	HMPSA44	1
Q504	511-001-2141 511-001-2746	2SK2141 2SK2746 (For PFC)	1
Q504 Heat Sink	120-001-P6SE-	Q504 Heat Sink	1
Q717	510-250-0122	TIF122	1
Silicon Rubber	540-100-2001	For Q717,Q719,D719	1
Shoulder Washers	540-500-2002-C	For Q717,Q719	1
Q703	510-023-5411	2SC5411	1
Q703 Heat Sink	120-001-P6SE-E	Q717,703,D709,Q719 H.S	1
Q707	511-005-0644	IRF644	1
Q719,709	511-005-0634	IRF634	2
LED901	520-005-73GD	5 ϕ LED	1
D304	520-010-4002	1N4002	1

D201,231,261,202,232,262,203,233 D263,503,507,518,532,601,602,603 D604,606,610,611,711A,713,714,716 D720,725,752,753, 901,902,904	520-001-4148	1N4148	31
D605	520-001-4148	1N4148	1
D703,704	520-001-4148	1N4148	2
D505,712,715,708	520-010-4936	1N4936	4
D707	520-010-4936	1N4936	1
D711	520-010-4937	1N4937	1
ZD702	521-005-03R6	HZ4A2 (3.6V)	1
ZD281,701,901,902,903,904.281	521-005-05R0	HZ5C1	7
ZD601,612	521-005-13R0	HZ13V	2
ZD551	521-005-18R0	HZ18V	1
ZD502	521-005-30R0	HZ30V	1
ZD501	521-005-56R0	HZ56V	1
D205.235.265	522-010-SS83	1SS83	3
D501	522-010-T42M	BYT42M	1
D513	522-020-H203	HER203	1
D508	522-020-H207-F	HER207G-F	1
D514,515,516,517	522-020-L205	RL205	4
D502,510	522-030-H303G-F	HER303G	2
D719	522-030-H305G-F	HER305G	1
D509	522-030-H305G	HER305G	1
D509 Heat Sink	120-001-0916-C	D509 Heat Sink	1
D709	522-050-023M	ESC023M-15	1
D705	522-010-5818	1N5818	1
X901	530-120-0001	RESONATOR,12MHz	1
F501	550-141-3000	3.15A,250V	1
FUSE CLIP	551-021-0001		2
Wire	620-040-0200	G3 to G3'	1
P502	630-002-2002	2P 1.56D Base	1
P701	630-004-3001	4P 2.36D Base	1
P281,505,TCO	630-001-3001	1P 2.36D	3
P601	630-002-1009	For X-Ray Test	1
P301,901	630-002-4001	2P 0.6D	2
P902	630-005-4001	For Signal Cable	1
P903	630-003-4003	3P Pitch 2.5mm	1
P905	630-009-1009	9P Pitch 2.0mm	1
P201	630-006-4001R	6P 2.0mm Base	1
P202	630-012-1009	12P 2.0mm Base	1

POWER CORD	600-151-2804D	150mm	1
SIGNAL CABLE	610-171-15801	Signal Cable	1
Rear Support Bracket	121-001-P6SE-B		1
Rear Bracket	121-002-P6SE-A		1
CRT Cover	123-004-P6SE		1
CRT DY Cover	123-002-768I-A	For TCO	1
CRT	700-119-246P 700-117-25PF-2 700-117-26SS 700-117-2806 700-115-2823	986NS 787NS 786NS 772NS 562NS	1
T703	730-400-770VC	Focus choke	1
T501	730-102-P6SE-A	Power Converter	1
T702	730-200-770VC	H-Driver	1
T701	730-302-P6SE	FBT	1
Degaussing Coil	735-017-X771-C		1
L200,260	745-R68-1162	0.68uH 1/2W	2
L230,201,231,261	745-R33-1162	0.33uH 1/2W	4
L703	745-151-2084	H-Size Coil 150uH	1
L704	745-720-2084	Step Up Coil 72uH	1
L502	750-100-770VC	Line-Filter	1
L503	750-150-K998	Line-Filter	1
B280,284,B283,L706,701,511,515, L900,R585,Q504(G)	760-100-0002	Bead Core	10
L506,507,508,509,510,512,701	760-000-0001	Bead Core	7
L703A	760-100-0001-T	Bead Cord	1
Ground Wire	800-100-772NS-A	For CRT	1
T505	730-122-P7SE-2	PFC Choke 180uF	1
C571	318-684-4052-Y	0.68uF 400V MM-CON	1
C572 ,574	307-103-3572	0.01uF 500V C.C	2
C573	307-471-3170	470pF 500V C.C	1
D552	522-023-H308	HER308G	1
D551	522-010-H105	HER105	1

J. CONDUCTION VIEW
MAIN BOARD (Component Side)

MAIN BOARD (Soild Side)

K. SCHEMATIC DIAGRAM

MEMO

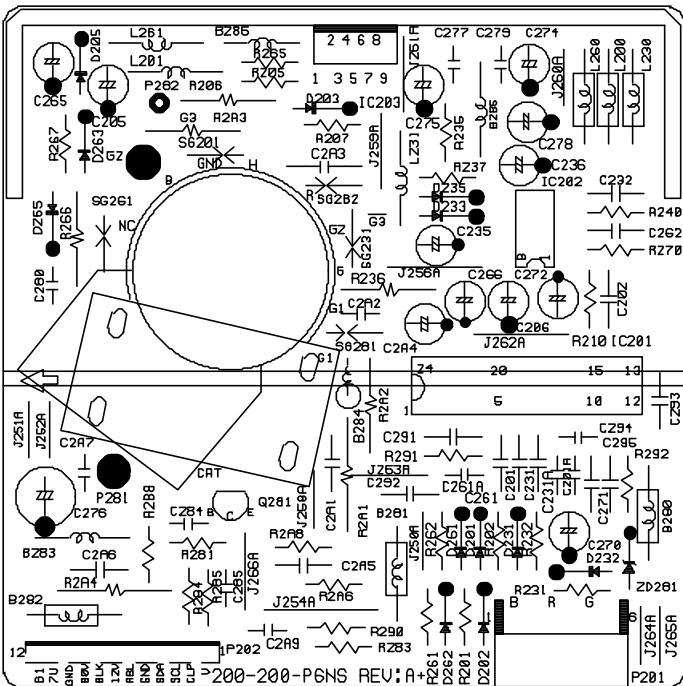

200-200-P6NS REV: A+

P201

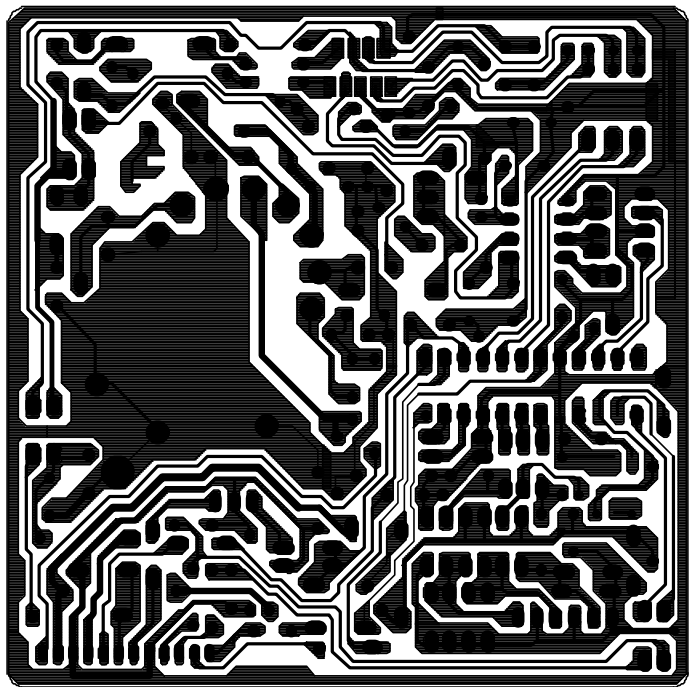

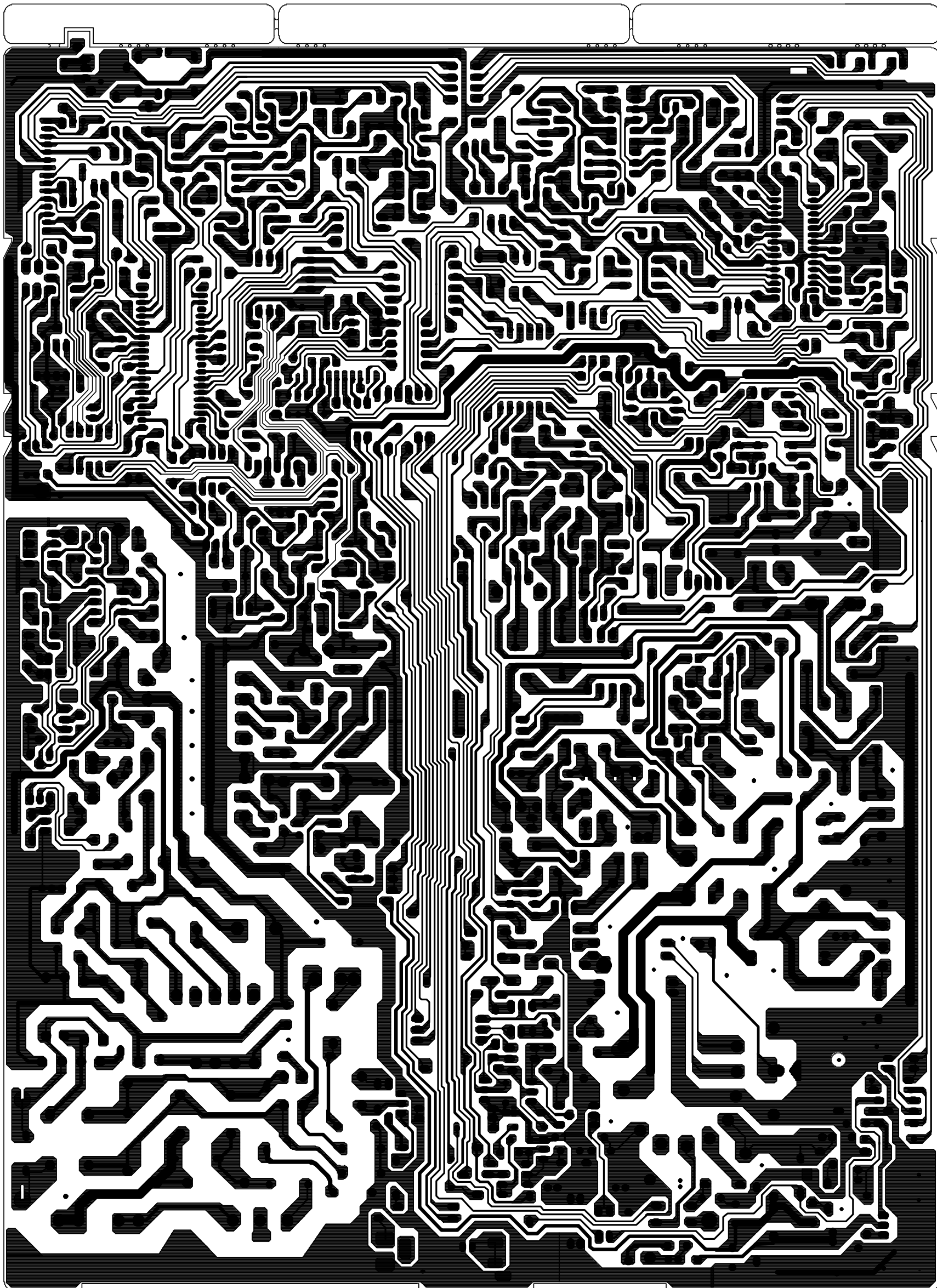

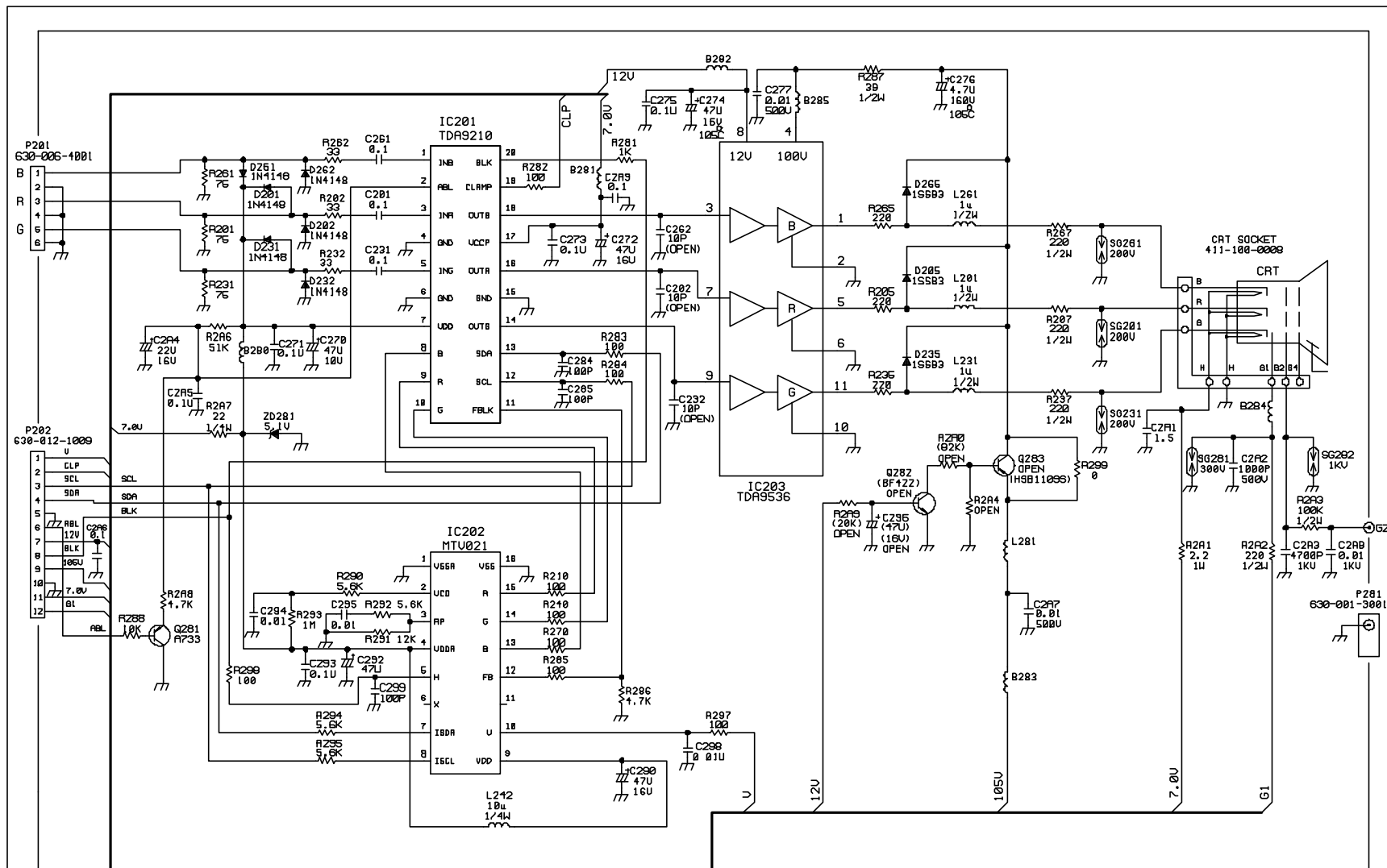

MAG TECHNOLOGY CO., LTD.	DRN	
786PF	DSN	
786PF-C, SCH	EKD	
DATE : 2001-05-11	0	APPD

